

CLUTCH TYPE 51

FIELD MOUNTING : F.M.

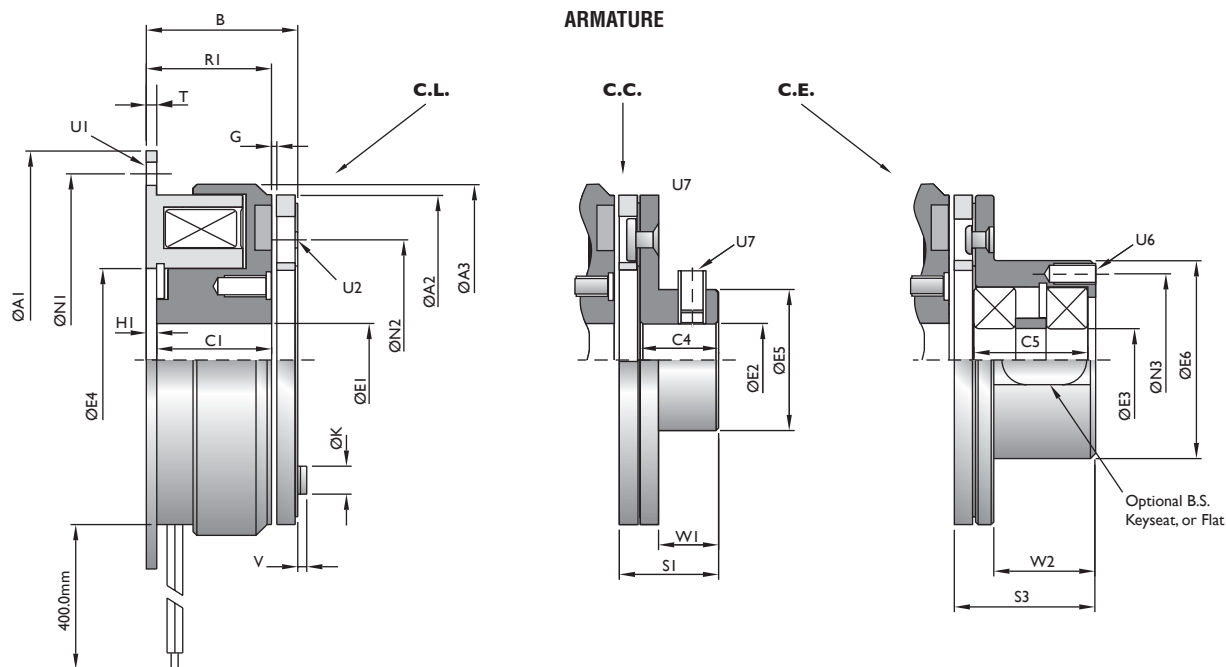

SIZE	TRQ TS Nm	MAX P20 w	A1 hg	A2	A3	B	C1	C4	C5	MAX E1 H7	MAX E2 H7	E3	E4 H8	E5	E6 kg	G	H1	K	N1	N2	N3	R1	S1	S3	T	U1 X4	U2	U6	U7	V	W1	W2
00	0.30	5	38	28.6	28	18.6	12.5	7	-	6.5	6.5	-	11	10	-	0.1	0.5	5	33.3	19.5	-	15.5	9.7	-	1.5	3.2	2x2.6	-	M3	1	4.5	-
01	0.60	6	38	30	31	18.5	13.6	10	-	6.5	6.5	-	11.5	12	-	0.1	0.5	5	33.3	19.5	-	16.5	12.8	-	1.5	3.2	2x2.6	-	M3	1	8	-
02	0.75	6	45	32	34	25	20.2	10	-	6.5	6.5	-	13	12	-	0.1	2	5	38	23	-	22.2	12.8	-	2	3.5	3x2.6	-	M3	1.5	8	-
03	1.20	8	54	40	43	28.5	23.4	12	-	10	10	-	19	17	-	0.15	2.2	6.1	47	30	-	25.6	15.3	-	2	3.5	3x3.1	-	M3	1.5	9.5	-
04	1.60	8	62	42	44	28.8	19	12	-	10	10	-	19	17	-	0.15	2.2	6.1	54	29	-	25.4	15.3	-	2	5	2x3.1	-	M3	1.5	9.5	-
05	3	10	65	50	54	31.8	26.1	12	12	15	15	7	26	24	30	0.2	2	6.1	58	38	24	28.1	15.3	18	2	3.5	3x3.1	3xM3	M4	1.5	9.5	12
06	8	15	80	63	66.5	28	22	15	20	17	17	12	35	27	38	0.2	2	6.1	72	46	33	24	19	27	2	4.5	3x3.1	3xM4	M5	1.5	11.5	20
07	8	15	89	63	68	36	22.5	15	20	15	17	12	27	27	38	0.2	95	6.1	79.5	46	33	32	17	27	2	5	3x3.1	3xM4	M5	1.5	11.5	20
08	16	18	100	80	85	31	24	20	23.5	22	20	15	42	32	45	0.2	2.5	8	90	60	37	26.5	24.7	34	2.5	5.5	3x4.1	3xM4	M5	2	16	25
10	32	31	125	100	107	36	27	25	32	30	30	20	52	42	55	0.2	3	9	112	76	47	30	30	41	3	6.5	3x5.1	4xM4	M6	2	19	30
11	32	25	143	105	107	42	33	25	32	25	30	20	47.6	42	55	0.2	4.7	9	127	76	47	38	30	41	3	7.5	3x5.1	4xM4	M6	2	20	30
12	65	32	150	125	133	41	30	30	42	40	35	25	62	49	64	0.3	3.5	10	137	95	52	33.5	37.2	53.5	3.5	6.5	3x6.1	4xM4	M6	2.5	24	40
16	120	45	190	160	170	47	38	38	54	50	40	30	80	65	75	0.3	3.5	13	175	120	62	37.5	48	66	4	9	3x8.2	6xM5	M8	9	30	50
20	240	65	230	200	213	54	40	48	67	65	60	40	100	92	90	0.5	4	16	215	158	75	44	59	80.9	5	9	3x10.2	4xM6	M8	11	39	60

Keyways to B.S. 4235 • Circlip Grooves to B.S. 3673 • Insulation Class B



CLUTCH TYPE 51

FIELD MOUNTING : S.B.

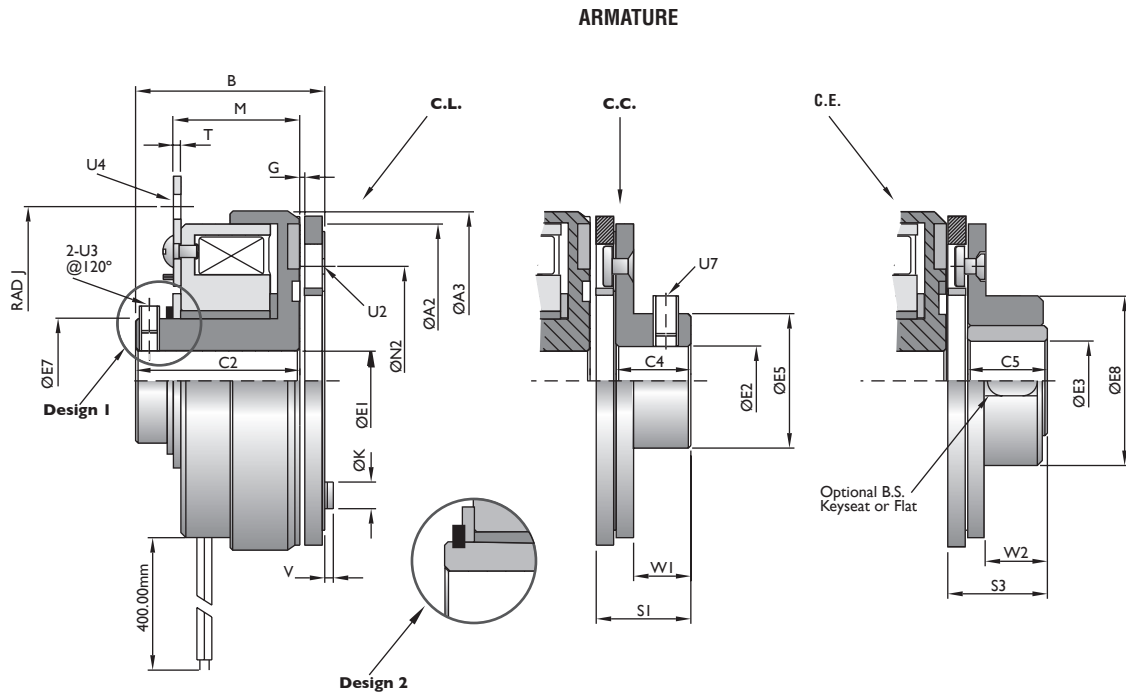

SIZE	TRQ TS Nm	MAX P20 W	A2	A3	B	C2	C4	C5	H7		E3	E5	E7	E8 h7	G	J	K	M	N2	S1	S3	T	U2	U3	U4	U7	V	W1	W2	DESIGN	
									MAX E1	MAX E2																				1	2
01	0.60	6	30	31	24	22	10	10	6	6.5	6	12	16	12.7	0.1	15.5	5	16	19.5	12.8	12.5	1.5	2x2.6	M3	HOLE 4x3.2	M3	1	8	7.5	•	
02	0.75	6	32	34	29	26	10	10	6	6.5	6	12	16	14	0.1	20	5	22	23	12.8	12.5	1.5	3x2.6	M3	SLOT 3.10	M3	1.5	8	7.5	•	
03	1.20	8	40	43	34	30.5	12	12	10	10	10	17	17	18	0.15	23	6.1	25	30	15.3	15	1.5	3x3.1	M3	SLOT 3.20	M3	1.5	9.5	9	•	
04	1.60	8	42	44	34	30.5	12	12	10	10	10	17	16	20	0.15	30	6.1	25	29	15.3	15	1.5	2x3.1	M3	SLOT 3.10	M3	1.5	9.5	9	•	
05	3	10	50	54	37.5	34	12	12	15	15	15	24	20	28	0.2	28	6.1	28	38	15.3	15	1.5	3x3.1	M4	SLOT 5.10	M4	1.5	9.5	9	•	
06	8	12	66.5	68	32	28	15	16	17	17	20	27	25	34	0.2	36	6.1	25.4	46	19	19	1.5	3x3.1	SLOT 5.10	M5	1.5	11.5	11.5	•		
07	8	12	66.5	68	40	36	15	16	17	17	20	27	25	35	0.2	40	6.1	27.5	46	19	19	1.5	3x3.1	M5	HOLE 5.10	M5	1.5	11.5	11.5	•	
08	16	18	80	85	36	31	20	20	20	20	25	32	35	48	0.2	45	8	27.8	60	24.7	24	1.5	3x4.1	SLOT 5.00	M5	2	16	15	•		

Keyways to B.S. 4235 • Insulation Class B



CLUTCH TYPE 51

FIELD MOUNTING : B.B.

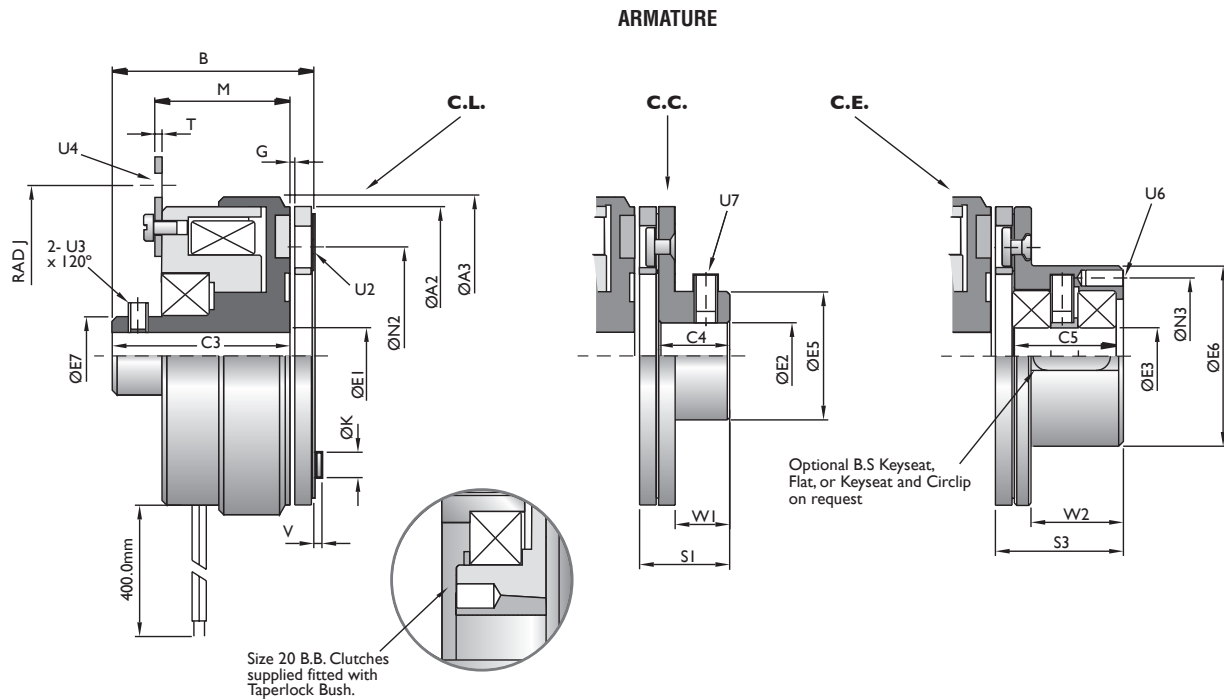

SIZE	TRQ TS (Nm)	Max P20 (w)	A2	A3	B	C3	C4	C5	Max E1 H7	Max E2 H7	E3	E5	E6 k6	E7	G	J	K	M	N2	N3	S1	S3	T	U2	U3	U4	U6	U7	V	W1	W2
05	3	10	50	54	33	30	12	12	8	15	7	24	30	10	0.2	28	6.1	26	38	24	15.3	18	1.5	3x3.1	M4	SLOT 5.10	3xM3	M4	1.5	9.5	12
06	8	12	63	67	44	40	15	20	12	17	12	27	38	16.5	0.2	36	6.1	28.5	46	33	19	27	1.5	3x3.1	M4	SLOT 5.10	3xM4	M5	1.5	11.5	20
07	8	12	66.5	68	40	36	15	20	12	17	12	27	38	16.5	0.2	40	6.1	28.5	46	33	19	27	1.5	3x3.1	M5	HOLE 5.10	3xM4	M5	1.5	11.5	20
08	16	18	80	85	37	32	20	23.5	17	20	15	32	45	25	0.2	45	8	28	60	37	24.7	34	1.5	3x4.1	M4	SLOT 5.00	3xM4	M5	2	16	25
10	32	25	100	107	55	49	25	32	25	30	20	42	55	35	0.2	58.5	9	39.1	76	47	30	41	2	3x5.1	M6	HOLE 5.50	4xM4	M6	2	19	30
11	32	25	105	107	52	46	25	32	25	30	20	42	55	35	0.2	58.5	9	39.1	76	47	30	41	2	3x5.1	M6	HOLE 5.50	4xM4	M6	2	19	30
13	65	32	125	133	59	52	30	42	28	35	25	49	64	40	0.3	71	10	43	95	52	37.2	53.5	2	3x6.1	M6	SLOT 6.10	4xM4	M6	2.5	25	40
16	120	45	160	170	71	62	38	54	40	40	30	65	75	60	0.3	92	13	52.5	120	62	48	66	2.5	3x8.2	M8	SLOT 8.10	6xM5	M8	9	30	50
20	240	50	200	213	53	43	40	67	40	60	40	83	90	80	0.5	127	16	52.5	158	75	50	80.9	3	3x10.2	-	SLOT 9.50	4xM6	M8	11	30.5	60

Keyways to B.S. 4235 • Insulation Class B

