

PERMANENT MAGNET HYSTERESIS CLUTCHES & BRAKES



FEATURES

ACCURATE AND DEPENDABLE TORQUE

Since torque is transmitted via a hysteresis field, there is minimal difference between the static and the dynamic torque. These units are unaffected by friction and wear, therefore torque is substantially more accurate and repeatable than friction tensioners.

STABLE TORQUE

A consistent torque is maintained regardless of allowable slip speed due to the hysteresis principle.

LONG LIFE

There is virtually no wear because permanent magnets and hysteresis disks transmit the torque by magnetic flux without physical contact.

SIMPLE INSTALLATION

Units are provided bearing mounted and pre-assembled.

NO CONTAMINATION

Units are sealed to protect against contamination from equipment. There are also no wear particles from operation to contaminate equipment.

NO ELECTRICAL POWER NEEDED

The PHT series clutches and brakes operate on a permanent magnet principle. External electrical connection is not required, therefore units function independently from power fluctuation.

CONSTANT TORQUE (ADJUSTABLE)

Units can deliver set torque regardless of speed range. Each unit's torque settings may be manually adjusted over a wide range providing great flexibility.

VERTICAL AND HORIZONTAL OPERATION POSSIBLE

Units can be mounted in any axis and can be run either clockwise or counter-clockwise without affecting performance.

LIGHT TORQUE HYSTERESIS BRAKE

SERIES 52-PHT-S

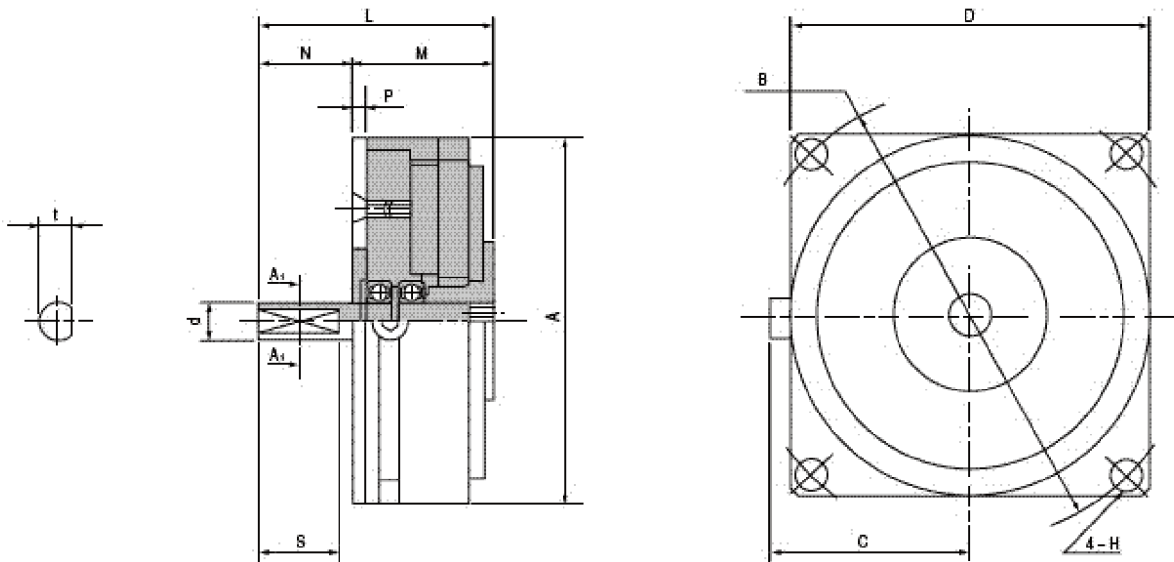

MODEL 52-PHT		0.02S	0.05S	0.5S
Torque range (Nm)		*0 - 0.003	*0 - 0.0075	0.001 - 0.060
Max slip speed (r/min)		1000	1000	1800
Max heat dissipation (W)		2.5	3	10
Moment of inertia JX 10-4	(Kgm ²)	0.0011	0.0048	0.103
	(Kgfc ²)	0.0045	0.0190	0.410
Shaft DIA (mm)	dg6	3	3	
	t	2.6	2.6	5.5
Radial dimensions (mm)	A	26	32	56
	B	34 +/- 0.2	40 +/- 0.2	70 +/- 0.2
	C	16.5	19.5	31.5
	D	30	35	56
	H	3.4	3.4	4.4
	L	28	28	36.5
	M	16.7	18	22
Axial dimensions (mm)	N	11.3	10	14.5
	P	2	2	2
	S	8	8	12
Weight (Kg)		0.06	0.09	0.35

HYSTERESIS BRAKE OR CLUTCH

SERIES 52-PHT-D

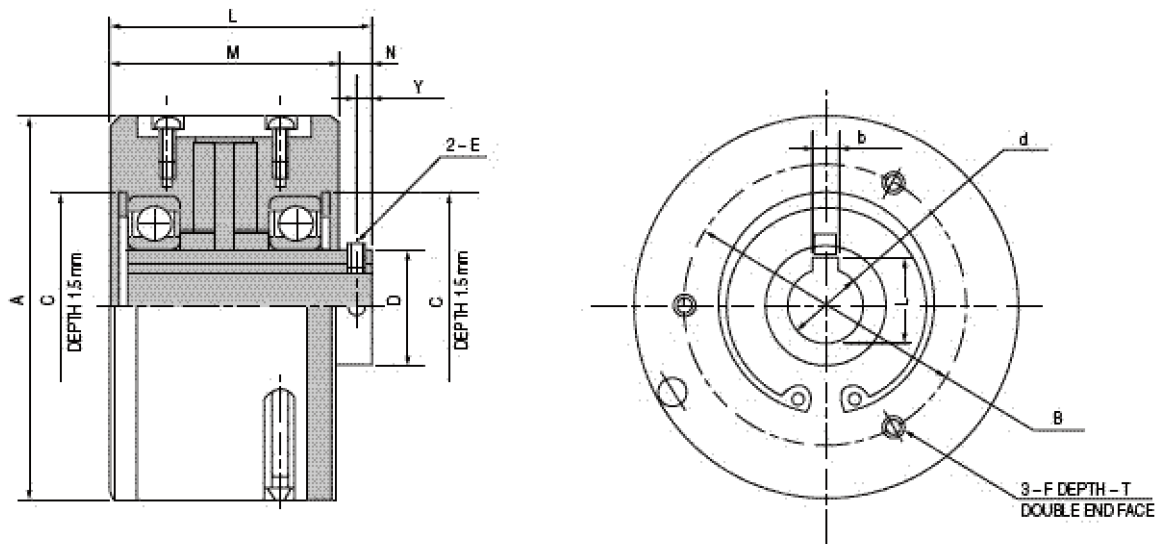

MODEL 52-PHT			1.2D	2.5D	5D
Torque range (Nm)			0.01 - 0.17	0.01 - 0.37	0.02 - 0.5
Max slip speed (r/min)			1800	1800	1800
Max heat dissipation (W)			15	20	30
Moment of inertia	JX 10-4	BODY SIDE	1.3	4.5	7.5
	(Kgfc ²)	SHAFT SIDE	0.078	0.243	0.4
Bore DIA & length (mm) dH7 x 1			6 X 37.5	6 X 40	8 X 43
KEYWAY bjs9 x t +0.1 / -0			-	-	3 X 9.4
Radial dimensions (mm)	A		47	60	70
	B		32 +/- 0.2	40 +/- 0.2	46 +/- 0.2
	CH7		22	28	28
	D		18	12	15
	E		M3	M3	M3
	F		M3	M3	M3
	T		6	6	6
Axial dimensions (mm)	L		39.5	42	45
	M		32.5	35	37
	N		7	7	8
	Y		3	3	4
Weight (Kg)			0.3	0.57	0.84

MODEL 52-PHT

MODEL 52-PHT		10D	30D	70D	
Torque range (Nm)		0.5 - 0.99	0.2 - 2.99	2.99 - 7.0	
Max slip speed (r/min)		1800	1000	700	
Max heat dissipation (W)		45	70	150	
Moment of inertia	JX 10-4	BODY SIDE	11.5	55	230
	(Kgfcm ²)	SHAFT SIDE	1.075	6.25	27.5
Bore DIA & length (mm) dH7 x 1		15 X 53.7	16 X 61	16 X 64	
KEYWAY bjs9 x t +0.1 / -0		5 X 17.3	5 X 18.3	5 X 18.3	
Radial dimensions (mm)	A	82	118	166	
	B	60 +/- 0.2	76.2 +/- 0.2	105 +/- 0.2	
	CH7	47	62	62	
	D	25	35	35	
	E	M4	M4	M4	
	F	M4	M5	M5	
	T	10	12	12	
Axial dimensions (mm)	L	57.2	65	68	
	M	50.1	55	59	
	N	7.1	10	9	
	Y	3.5	6	6	
Weight (Kg)		1.6	3.6	7.9	

* No torque except miniscule bearing contact and seal drag.